

“Hot Standby” Switching



Products:

DEV 1991/zz/m*n+1 - $m*n+1$ CATV-Band Redundancy Switch

DEV 1993/zz/m*n+1 - $m*n+1$ L-Band Redundancy Switch

Features:

- Series of Redundancy Switches with n Signal Channels (2, 4, 6, 8, 10, 12, 14 or 16) and one Redundancy Channel which define a Redundancy Unit. m is the number (1, 2 or 4) of Redundancy Units to be switched in parallel
- Versions for CATV-Band and L-Band with 50 Ohm and 75 Ohm Impedance (zz) available
- 19" Chassis for Rack Integration (Height of the Housing depends on the Number of I/Os)
- Configuration, Surveillance and Control via convenient Web Interface
- Remote Control Support, e.g. SNMP
- Autonomous Switching to the Redundancy Channel(s) based on the RF Sensing Information.
- Built-in Antenna Controller optional:
Automatic Antenna Positioning, Reposition for Backup, Redundancy Applications
Convenient Setup and Remote Control of Motorized Antenna(s) or Backup Antenna(s) via a comprehensive and easy to use Web Interface

Application Areas:

- Satellite Ground Stations
- Cable Head End Stations
- DAB-T with Satellite Input
- Digital TV



Front DEV 1993/zz/m*4+1



Rear DEV 1993/75/4*4+1

The Service Uptime Challenge

High uptime is critical for most satellite ground station signals. Failure of a single device in the transmission chain can affect large numbers of services - making the need for smart, automated, backup protection systems as important as ever, whether it is for redundancy protection of modulators, IF or L-Band signals, multiplexed ASI or broadband signals, CATV or optical transmission paths.

Introducing the DEV Solution

To meet application-specific requirements in satellite earth stations, L-Band distribution systems, and CATV RF distribution systems, DEV has developed a series of $m*n+1$ redundancy switches that offer important advantages for operators.

This means, that n number of primary signal channels are protected by an additional backup or "redundancy" channel, which can restore signal transport if one of the primary signal channels fails. DEV refers to the bank of primary and backup channels $n+1$ as a "Redundancy Unit". DEV 1991 or DEV 1993 switch Redundancy Units can have $n = 2, 4, 6, 8, 10, 12, 14,$ or 16 signal channels. In addition, configurations are available for $m = 1, 2,$ or 4 separate Redundancy Units (or $m*n+1$ configurations) within a single switch. These can be used, for example, to provide separate banks of redundant transmission paths serving multiple satellite antennas, each on separate Redundancy Units having $n+1$ internal redundancy protection.

The height of the chassis of this series ranges from 3 RU up to 9 RU depending on the size and the number of Redundancy Units.

The Technical Concept

The DEV 1991 and DEV 1993 have similar functionalities; the field of application varies due to their different frequency range. The DEV 1991 is applied for systems, which are in the range of the CATV-Band and the DEV 1993 can handle frequencies up to 2.3 GHz.

The devices are available in 50 Ohm with SMA connectors or in 75 Ohm with precision F connectors or BNC connectors.

A further distinction is whether the instrument is set up as Input Redundancy Configuration (default) or Output Redundancy Configuration (on request); please refer to the next page for an explanation and application examples for the different configurations.

The local control user interface for the device is supplemented by a convenient Web Interface that can configure, switch, and monitor the device.

SNMP and other remote control protocol support makes integration with Monitor & Control (M&C) systems easier.

Additionally, the device is capable to switch automatically to redundancy, based on the RF sensing information which is continuously monitored for all channels of the device.

With Option 30, the product can be extended to setup and to control a motorized backup redundancy antenna via an antenna controller – and create a backup system to restore a failed antenna path and switch restoral signals to that path. Thus, a system is established to perform the automatic positioning of the motorized antenna and the redundancy switching.

Input Redundancy Configuration vs. Output Redundancy Configuration

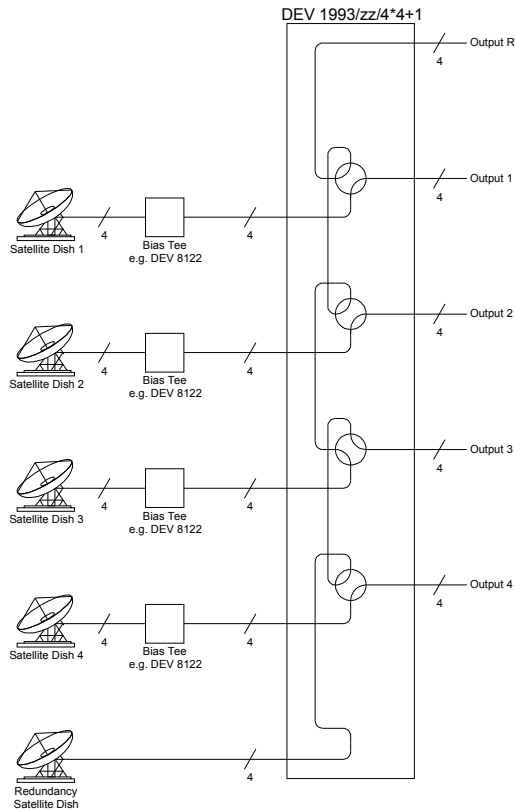

Input Redundancy Example

An antenna farm with one backup (or redundancy) dish is a typical example of an input redundancy application.

In "normal" operational mode each of the signals (here 4 per antenna) is routed to the corresponding output. If an antenna fails, the redundancy dish takes over the task of the failed antenna. The redundancy antenna signals are routed to the switch output channel previously fed by the failed dish, thus providing a "hot standby" restoral of service.

The figure above shows a 4+1 antenna system utilizing a DEV 1993/zz/4*4+1 (the impedance zz may be chosen for the specific application). Note, that the bias supply for the redundancy antenna is provided by the DEV 1993 and that the figure shows Output 3 to be supplied by the Redundancy Satellite Dish instead of Satellite Dish 3. The signals of Satellite Dish 3 are not routed to Output R', if it is switched to redundancy, as may be implied by the figure!

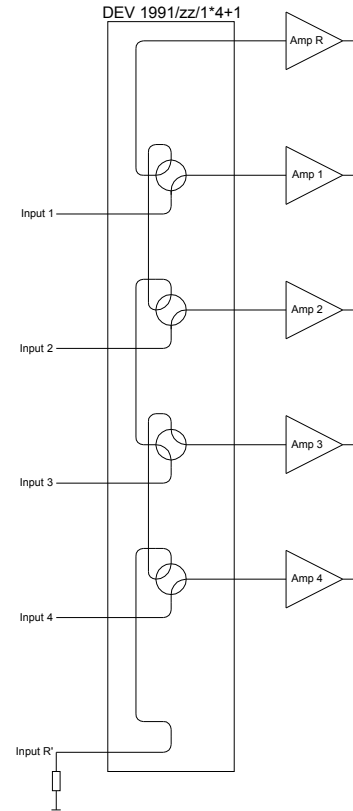

Output Redundancy Example

An example for an output redundancy system is a ground station with a number of line amplifiers plus one redundancy amplifier:

In normal operation mode each of the amplifiers provides a fail-over "hot standby", and if an amplifier fails, the redundancy amplifier (Amp R in the example figure above) takes over the task of the failed amplifier. The redundancy amplifier is then fed by the signal input of the defective amplifier thereby providing an instant restoral of service.

The figure shows a 4+1 output redundancy system utilizing a DEV 1991/zz/1*4+1. Here this means that the spare amplifier is terminated on its input if it is not in use. The figure above shows the redundancy amplifier Amp R to be supplied by Input 3. The signal at Input R' (here: the termination) is not routed to Amp 3 if it is switched to redundancy, as may be implied by the figure.

Technical Data

DEV 1991/zz/m*n+1 / DEV 1993/zz/m*n+1 Redundancy Switches

RF Specifications

Frequency range	47...862 MHz ¹ 950...2150 MHz ² 700...2300 MHz ²	(DEV 1991/zz/m*n+1); (DEV 1993/50/m*n+1); (DEV 1993/75/m*n+1)
Number of redundancy units (m)	1, 2 or 4	
Number of signal channels (n) per redundancy unit	2, 4, 6, 8, 10, 12, 14 or 16	
Impedance (zz), connectors	50 Ohm, SMA (f) 75 Ohm, BNC (f) 75 Ohm, Precision F (f)	(DEV 1991/50/m*n+1, DEV 1993/50/m*n+1); (DEV 1991/75/m*n+1); (DEV 1993/75/m*n+1)
Return loss (signal path)	>16 dB >14 dB	(DEV 1991/zz/m*n+1); (DEV 1993/zz/m*n+1)
Insertion loss (signal path)	<1.5 dB <2 dB <2.5 dB	(DEV 1991/50/m*n+1); (DEV 1993/50/m*n+1); (DEV 1991/75/m*n+1, DEV 1993/75/m*n+1)
Insertion loss (redundancy path)	<3.5 dB <4.5 dB <5 dB	(DEV 1991/50/m*n+1); (DEV 1991/75/m*n+1); (DEV 1993/zz/m*n+1)
Isolation between input ports	>70 dB >60 dB	(DEV 1991/zz/m*n+1); (DEV 1993/zz/m*n+1)
Group delay distortion	<7 ns	
Relay type	Latching	
Switching power	<30 dBm	
Switching cycles	>10E6	

Bias & Bias Current Monitoring (DEV 1993/zz/m*n+1 in Input Redundancy Configuration, only)

Bias	15 V DC, max. 500 mA (per redundancy module)	
Adjustable level setting:		
• Upper alarm level	max. 500 mA	(DEV factory setting: 350 mA)
• Lower alarm level	min. 0 mA	(DEV factory setting: 150 mA)
Alarm indication	via LED & via remote communication	

RF Sensing

Adjustable threshold level	0 dBm > threshold level > -60 dBm (DEV factory setting: -40 dBm)
Alarm indication	via LED & via remote communication

Remarks

- ¹ All signal and redundancy paths are capable of passing through a DC voltage
- ² All signal paths are capable of passing through a DC voltage through in normal operation mode.

Technical Data (cont.)

Remote Communication

Interfaces (connectors)

- Ethernet (RJ-45);
- serial interface RS 232 optional RS 422/485 (Sub-D-9 (f));
- Option 30: additional serial interface for antenna controller.

Remote control & surveillance (interface)

- via Web Interface (Ethernet);
- via SNMP (Ethernet).

without Option 30 additionally:

- via Sandar Prosan protocol, (serial interface); *OR*
- via Leitch protocol (Ethernet/Telnet (up to 7 sessions) and via serial interface); *OR*
- via QEC protocol (Ethernet (Telnet port 23) and via serial interface).

Redundant Power Supply

Redundant power supplies

100...240 V AC supplied by two different lines (standard)
or

-40...-56 V DC supplied by two different lines (Option 14)

Power consumption

<100...200 VA (depending on configuration)

Potential Free Contacts

Alarm connector

Sub-D-9 (m)

Contact load

60 V; 300 mA

Summary Alarm

Via remote interface and via potential free contacts

Two Stage Alarm Signalization for Power Line Failure:

B-Alarm

One power supply unit does not deliver any secondary power.

A-Alarm

All power supply units do not deliver any secondary power.

General Specifications

Housing

19" (483 mm), 495 mm depth, height (depending on configuration):
1 chassis: 3 RU (133 mm),
2 chassis: 6 RU (266 mm),
3 chassis: 9 RU (400 mm)

Weight

~8...25 kg (depending on configuration)

Environmental conditions

ETS 300019 Part 1-3 Class 3.1

Order Information

All redundancy switches DEV 199x/zz/m*n+1 are available for the CATV-Band and for the L-Band. The impedances (50 Ohm with SMA connectors or 75 Ohm with precision F connectors or BNC connectors) can be selected. When ordering, please specify the number of redundancy units (1, 2, or 4), and the number of signal channels (2, 4, 6, 8, 10, 12, 14, or 16) per redundancy unit.

For your order, please specify:

x: 1 = CATV-Band OR 3 = L-Band
 zz: 50 = 50 Ohm Inputs & Outputs OR 75 = 75 Ohm Inputs & Outputs
 m: number of redundancy units: 1, 2 or 4
 n: number of signal channels per redundancy units: 2, 4, 6, 8, 10, 12, 14, or 16

e.g. DEV 1993/50/4*10+1 = L-Band Redundancy Switch, Inputs & Outputs 50 Ohm, 4 redundancy units with 10 signal channels each [9 RU]

The size of the instrument (i.e. 1*, 2* or 3* 3 RU chassis) depends on the size of m and n:

DEV 199x/zz/1*n+1	1*n+1 Redundancy Switch 3 RU [m = 1, n = 2...16]
DEV 199x/zz/2*n+1	2*n+1 Redundancy Switch 3 RU [m = 2, n = 2...8]
DEV 199x/zz/4*n+1	4*n+1 Redundancy Switch 3 RU [m = 4, n = 2 or 4]
DEV 199x/zz/2*n+1	2*n+1 Redundancy Switch 6 RU [m = 2, n = 10...16]
DEV 199x/zz/4*n+1	4*n+1 Redundancy Switch 6 RU [m = 4, n = 6 or 8]
DEV 199x/zz/4*n+1	4*n+1 Redundancy Switch 9 RU [m = 4, n = 10...16]

By default, all redundancy switches are delivered in Input Redundancy Configuration. If your application requires a redundancy switch in Output Redundancy Configuration, this is possible as well.

Please contact DEV Systemtechnik to discuss your special requirements!

Option 14	-40...-56 V DC Supply Voltage
Option 30	Monitoring & Control of a Motorized Antenna (in combination with a DEV 1993/zz/m*n+1 in Input Redundancy Configuration, only)
	Option 30 needs to be supplemented by the appropriate cable:
DEV 78-0128	Antenna Controller Interface Cable for SVS Satellite Systems AKS 200 Antenna Controller
DEV 78-0129	Antenna Controller Interface Cable for Research Concepts Inc. RC2000 Dual Axis Antenna Controller
Option 52	RS 422 instead of RS 232
Option 53	RS 485 instead of RS 232

Contact

DEV Systemtechnik GmbH & Co. KG
 Grüner Weg 4A
 D-61169 Friedberg, Germany
 Phone: +49 (0) 6031 18999-0
 Fax: +49 (0) 6031 18999-15
 info@dev-systemtechnik.com
 www.dev-systemtechnik.com

DEV America LP
 4695 MacArthur Court, Suite 1117
 Newport Beach, CA 92660, USA
 Phone: (949) 798-6120
 Fax: (949) 798-6121
 info@dev-america.com
 www.dev-america.com

Rev. 29-NOV-2011